



INGÉNIERIE DES  
CHEMINEMENTS



**OBPlast OBP**  
CHEMIN DE CÂBLES PVC

[WWW.OB-PROFILS.COM](http://WWW.OB-PROFILS.COM)



UNE-EN 61537  
UNE-EN 50085



UNE-EN 61537  
UNE-EN 50085  
UNE 23727  
UL94



UNE-EN 60695

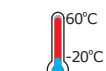

UNE-EN 61537



UNE-EN 50085

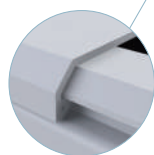

OB-Plast

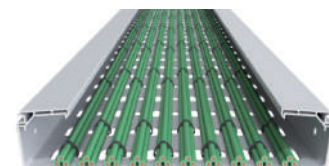

Mod. 60x100 10J  
UNE-EN 61537  
UNE-EN 50085



IEC 60529



IEC 50102



ISO/TR 10358  
DIN 8061



COBP



CPOBP



CCPOBP



CCOBP



CCCOBP



CXOBP



CCXOBP



DOBP



TFOBP



CSOBP



EOBP



ECOBP-AB



BOBP

Ob-Plast OBP2 / H60



3m (10ft)	H		B		7035	
	mm	inch	mm	inch	PVCM1 UV	KG/M
OBP2 60X100	60	2 3/8"	100	4"	560100UV	0.73
OBP2 60X150	60	2 3/8"	150	6"	560150UV	0.98
OBP2 60X200	60	2 3/8"	200	8"	560200UV	1.45
OBP2 60X300	60	2 3/8"	300	12"	560300UV	2.34

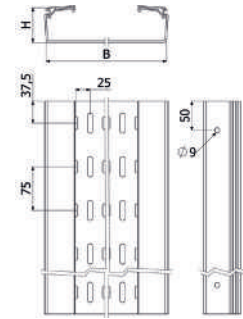

Ob-Plast OBP2-G / H60



3m (10ft)	H		B		7035	
	mm	inch	mm	inch	PVCM1 UV	KG/M
OBP2-G 60X100	60	2 3/8"	100	4"	580100UV	0.77
OBP2-G 60X150	60	2 3/8"	150	6"	580150UV	1.03
OBP2-G 60X200	60	2 3/8"	200	8"	580200UV	1.54
OBP2-G 60X300	60	2 3/8"	300	12"	580300UV	2.48

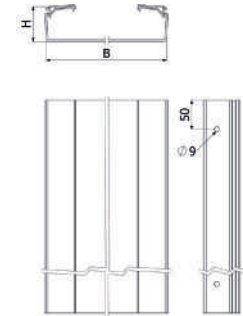

Ob-Plast OBP3 / H100



3m (10ft)	H		B		7035	
	mm	inch	mm	inch	PVCM1 UV	KG/M
OBP3 100X200	100	4"	200	8"	510200UV	2.25
OBP3 100X300	100	4"	300	12"	510300UV	3.63
OBP3 100X400	100	4"	400	16"	510400UV	4.30
OBP3 100X600	100	4"	600	24"	510600UV	6.40

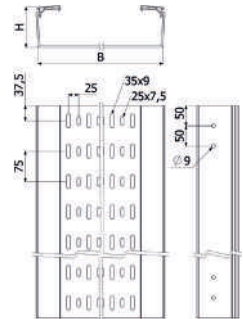

Ob-Plast OBP3-G / H100



3m (10ft)	H		B		7035	
	mm	inch	mm	inch	PVCM1 UV	KG/M
OBP3-G 100X200	100	4"	200	8"	597200UV	2.38
OBP3-G 100X300	100	4"	300	12"	597300UV	3.45
OBP3-G 100X400	100	4"	400	16"	597400UV	4.54
OBP3-G 100X600	100	4"	600	24"	597600UV	6.72

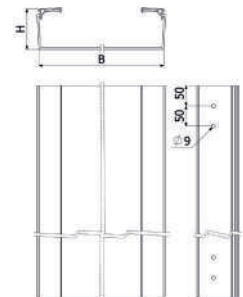

COUVERCLE COBP



3m (10ft)	B		7035	
	mm	inch	PVCM1 UV	KG/M
COBP 100	100	4"	555100UV	0.37
COBP 150	150	6"	555150UV	0.50
COBP 200	200	8"	555200UV	0.77
COBP 300	300	12"	555300UV	1.10
COBP 400	400	16"	555400UV	1.53
COBP 600	600	24"	555600UV	2.10

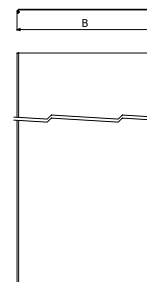

**COUDE PLAT CPOBP**



CPOBP	H		B		C		R		7035	
	mm	inch	mm	inch	mm	inch	mm	inch	PVCM1 UV	KG/UD
CPOBP 60X100	60	2 3/8"	100	4"	220	8 1/2"	80	3 1/2"	570110UV	0.40
CPOBP 60X150	60	2 3/8"	150	6"	220	8 1/2"	80	3 1/2"	570115UV	0.54
CPOBP 60X200	60	2 3/8"	200	8"	220	8 1/2"	80	3 1/2"	570120UV	0.91
CPOBP 60X300	60	2 3/8"	300	12"	220	8 1/2"	80	3 1/2"	570130UV	1.61
CPOBP 100X200	100	4"	200	8"	220	8 1/2"	80	3 1/2"	570220UV	1.24
CPOBP 100X300	100	4"	300	12"	220	8 1/2"	80	3 1/2"	570230UV	2.14
CPOBP 100X400	100	4"	400	16"	220	8 1/2"	80	3 1/2"	570240UV	3.27
CPOBP 100X600	100	4"	600	24"	240	9 1/2"	100	4"	570260UV	4.08

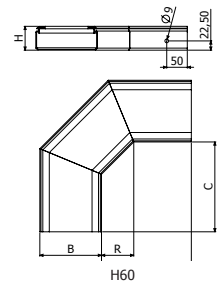

**COUVERCLE  
COUDE PLAT CCPOBP**



CCPOBP	B		C		7035	
	mm	inch	mm	inch	PVCM1 UV	KG/UD
CCPOBP 100	100	4"	220	8 1/2"	570110CUV	0.18
CCPOBP 150	150	6"	220	8 1/2"	570115CUV	0.26
CCPOBP 200	200	8"	220	8 1/2"	570120CUV	0.43
CCPOBP 300	300	12"	220	8 1/2"	570130CUV	0.71
CCPOBP 400	400	16"	220	8 1/2"	570140CUV	1.12
CCPOBP 600	600	24"	240	9 1/2"	570160CUV	1.94

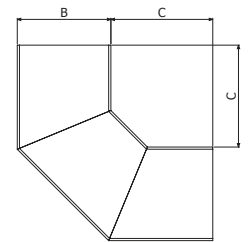

**COUDE CONCAVE CCOBP**



CCOBP	H		B		C		R		7035	
	mm	inch	mm	inch	mm	inch	mm	inch	PVCM1 UV	KG/UD
CCOBP 60X100	60	2 3/8"	100	4"	240	9 1/2"	100	4"	570110-IUV	0.39
CCOBP 60X150	60	2 3/8"	150	6"	240	9 1/2"	100	4"	570115-IUV	0.49
CCOBP 60X200	60	2 3/8"	200	8"	240	9 1/2"	100	4"	570120-IUV	0.78
CCOBP 60X300	60	2 3/8"	300	12"	240	9 1/2"	100	4"	570130-IUV	1.19
CCOBP 100X200	100	4"	200	8"	275	10 3/4"	115	4 1/2"	570220-IUV	1.37
CCOBP 100X300	100	4"	300	12"	275	10 3/4"	115	4 1/2"	570230-IUV	1.98
CCOBP 100X400	100	4"	400	16"	275	10 3/4"	115	4 1/2"	570240-IUV	2.55
CCOBP 100X600	100	4"	600	24"	275	10 3/4"	115	4 1/2"	570260-IUV	3.23

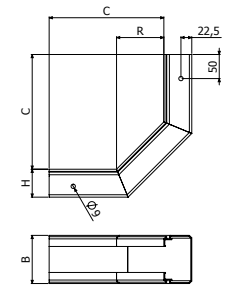

**COUVERCLE  
COUDE CONCAVE CCCOBP**



CCCOBP	B		7035	
	mm	inch	PVCM1 UV	KG/UD
CCCOBP 60X100	100	4"	570110-ICUV	0.18
CCCOBP 60X150	150	6"	570115-ICUV	0.24
CCCOBP 60X200	200	8"	570120-ICUV	0.37
CCCOBP 60X300	300	12"	570130-ICUV	0.52
CCCOBP 100X200	200	16"	570220-ICUV	0.56
CCCOBP 100X300	300	12"	570230-ICUV	0.61
CCCOBP 100X400	400	16"	570240-ICUV	0.81
CCCOBP 100X600	600	24"	570260-ICUV	1.04

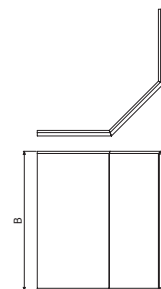

**DÉRIVATION DOBP PVC**



DOBP	7035	
	PVCM1 UV	KG/UD
DOBP 60	595000-60UV	0.24
DOBP 100	595000-100UV	0.48

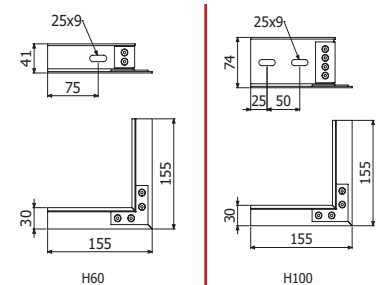

COUDE CONVEXE CXOBP



CXOBP	H		B		C		R		7035	
	mm	inch	mm	inch	mm	inch	mm	inch	PVCM1 UV	KG/UD
CXOBP 60X100	60	2 3/8"	100	4"	240	9 1/2"	100	4"	570110-EUV	0.39
CXOBP 60X150	60	2 3/8"	150	6"	240	9 1/2"	100	4"	570115-EUV	0.49
CXOBP 60X200	60	2 3/8"	200	8"	240	9 1/2"	100	4"	570120-EUV	0.78
CXOBP 60X300	60	2 3/8"	300	12"	240	9 1/2"	100	4"	570130-EUV	1.19
CXOBP 100X200	100	4"	200	8"	275	10 3/4"	115	4 3/8"	570220-EUV	1.37
CXOBP 100X300	100	4"	300	12"	275	10 3/4"	115	4 3/8"	570230-EUV	1.98
CXOBP 100X400	100	4"	400	16"	275	10 3/4"	115	4 3/8"	570240-EUV	2.55
CXOBP 100X600	100	4"	600	24"	275	10 3/4"	115	4 3/8"	570260-EUV	3.23

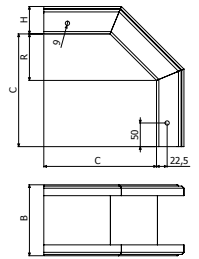

COUVERCLE COUDE CONVEXE TCXOBP



CCXOBP	B		7035	
	mm	inch	PVCM1 UV	KG/UD
CCXOBP 60X100	100	4"	570110-ECUV	0.22
CCXOBP 60X150	150	6"	570115-ECUV	0.30
CCXOBP 60X200	200	8"	570120-ECUV	0.49
CCXOBP 60X300	300	12"	570130-ECUV	0.65
CCXOBP 100X200	200	16"	570220-ECUV	0.75
CCXOBP 100X300	300	12"	570230-ECUV	0.82
CCXOBP 100X400	400	16"	570240-ECUV	1.14
CCXOBP 100X600	600	24"	570260-ECUV	1.39

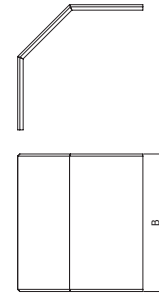

EMBOUIT FIN DE SECTION TFOBP PVC



TFOBP	H		B		7035	
	mm	inch	mm	inch	PVCM1 UV	KG/UD
TFOBP 60X100	60	2 3/8"	100	4"	B-560110UV	0.09
TFOBP 60X150	60	2 3/8"	150	6"	B-560115UV	0.13
TFOBP 60X200	60	2 3/8"	200	8"	B-560120UV	0.15
TFOBP 60X300	60	2 3/8"	300	12"	B-560130UV	0.21
TFOBP 100X200	100	4"	200	8"	B-560220UV	0.24
TFOBP 100X300	100	4"	300	12"	B-560230UV	0.31
TFOBP 100X400	100	4"	400	16"	B-560240UV	0.40
TFOBP 100X600	100	4"	600	24"	B-560260UV	0.55

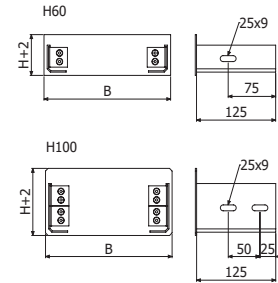

CORNIÈRE DE SÉPARATION PSOBP



CSOBP	H		7035	
	mm	inch	PVCM1 UV	KG/M
CSOBP 60	60	2 3/8"	502050UV	0.09
CSOBP 100	100	4"	502100UV	0.13

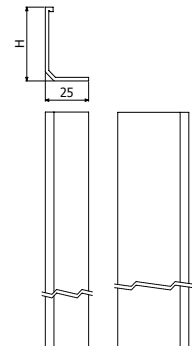

KIT ECOBP-AB\*



KIT ECOBP-AB	H		7035	
	mm	inch	PVCM1 UV	KG/UD
ECOBP-AB 60	60	2 3/8"	590260UV	0.1
ECOBP-AB 100	100	4"	590096UV	0.2

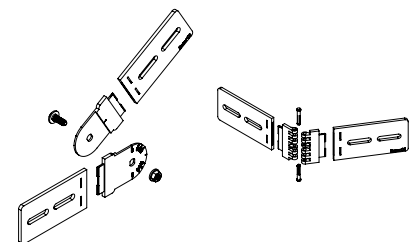

\* Peut être utilisée en Compas ou en Eclisses d'angle

**RAIL OBP-EDF / OBP-EDFR**



OBP-EDF	7035	
	Z275 RAL 7035	KG/UD
OBP-EDF 2M	564340-2000	2.29
OBP-EDFR 600	564340-600UV	2.05

OBP-EDFR	7035	
	PVCM1 UV	KG/UD
BOUCHON EDF	564000	0.25

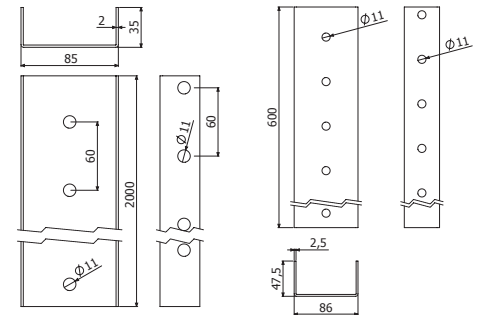

**ECLISSE EOBP**



EOBP	H		7035	
	mm	inch	PVCM1 UV	KG/UD
EOBP 60	60	2 3/8"	560060UV	0.05
EOBP 100	100	4"	510010UV	0.09

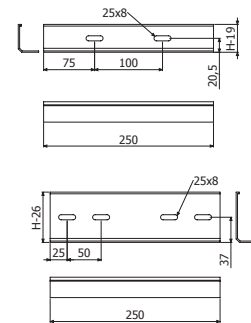

**ENSEMBLE BOBP**



BOBP	7035	
	PVCM1 UV	KG/UD
BOBP-100	550820UV	0.40

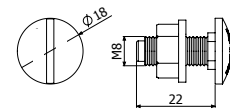

**ECLISSE JUOBP-C**



JUOBP-C	B		7035	
	mm	inch	PVCM1 UV	KG/UD
JUOBP-C	400	-	561300UV	0.30

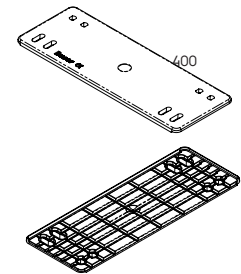

**GOUSSET KSHGR**



KSHGR	7035	
	Z275 RAL 7035	KG/UD
KSHGR	564360UV	0.61

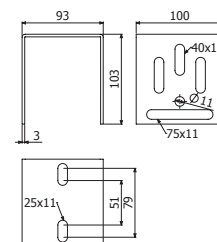

**ENSEMBLE CT2**



CT2	7035	
	I304L	KG/UD
CT2 M10X100	431100	0.11

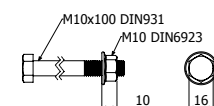

RA50



RA50	7035	
	PVCM1 UV	KG/M
RA50	512162UV	0.33

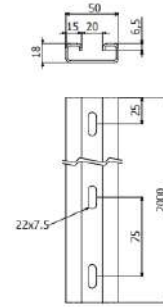

BRIDE BIK10-OBP\*



BIK10-OBP	e mm	Mod HxB	7035	
			i304	KG/UD
BIK10-OBP 60X100	1.5	60x100	400100	0.03
BIK10-OBP 60X150	1.5	60x150	400150	0.05
BIK10-OBP 60/100X200	1.5	60/100x200	400200	0.07
BIK10-OBP 60/100X300	1.5	60/100x300	400300	0.09
BIK10-OBP 100X400	2	100x400	400400	0.20
BIK10-OBP 100X600	2	100x600	400600	0.49

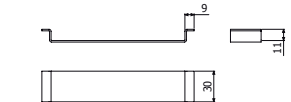

\* Pour une résistance IK10

CONSOLES OBPHG



OBPHG	L		7035	
	mm	inch	PVCM1 UV	KG/UD
OBPHG 100	100	4"	553100UV	0.19
OBPHG 150	150	6"	553150UV	0.27
OBPHG 200	200	8"	553200UV	0.34
OBPHG 300	300	12"	553300UV	0.54
OBPHG 400	400	16"	553400UV	0.95
OBPHG 600	600	24"	553600UV	1.10

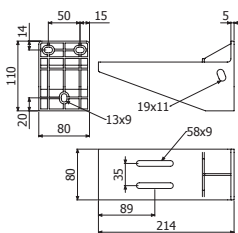
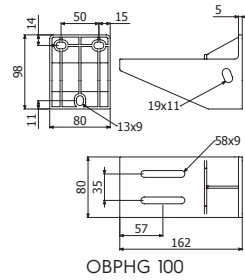

OBPHG 150

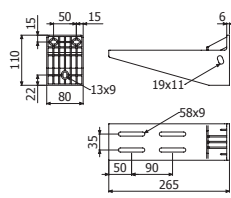

OBPHG 200

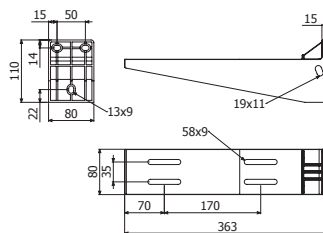

OBPHG 300

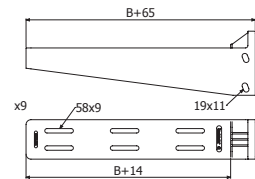

OBPHG 400/600

CONSOLES OBPGV



OBPGV	B		7035	
	mm	inch	PVCM1UV	KG/UD
OBPGV 100	100	4"	552100UV	0.23
OBPGV 150	150	6"	552150UV	0.26
OBPGV 200	200	8"	552200UV	0.28
OBPGV 300	300	12"	552300UV	0.33
OBPGV 400	400	16"	552400UV	0.38
OBPGV 600	600	24"	552600UV	0.48

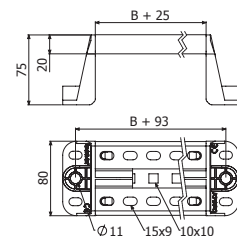



INGÉNIERIE DES  
CHEMINEMENTS



## OB Profils

1 AVENUE DE MALAGUET  
28360 PRUNAY-LE-GILLON  
FRANCE  
+33 (0)2 37 300 301

INFO@OB-PROFILS.FR  
WWW.OB-PROFILS.COM